

FIGURE H-1 **Rev. 2**
 Land Ownership, Project Area, and Location of
 Existing and Proposed Substations and
 Proposed Transmission Route (Sheet 7 of 7)
**EAGLE ROCK ENRICHMENT FACILITY
 ENVIRONMENTAL REPORT**

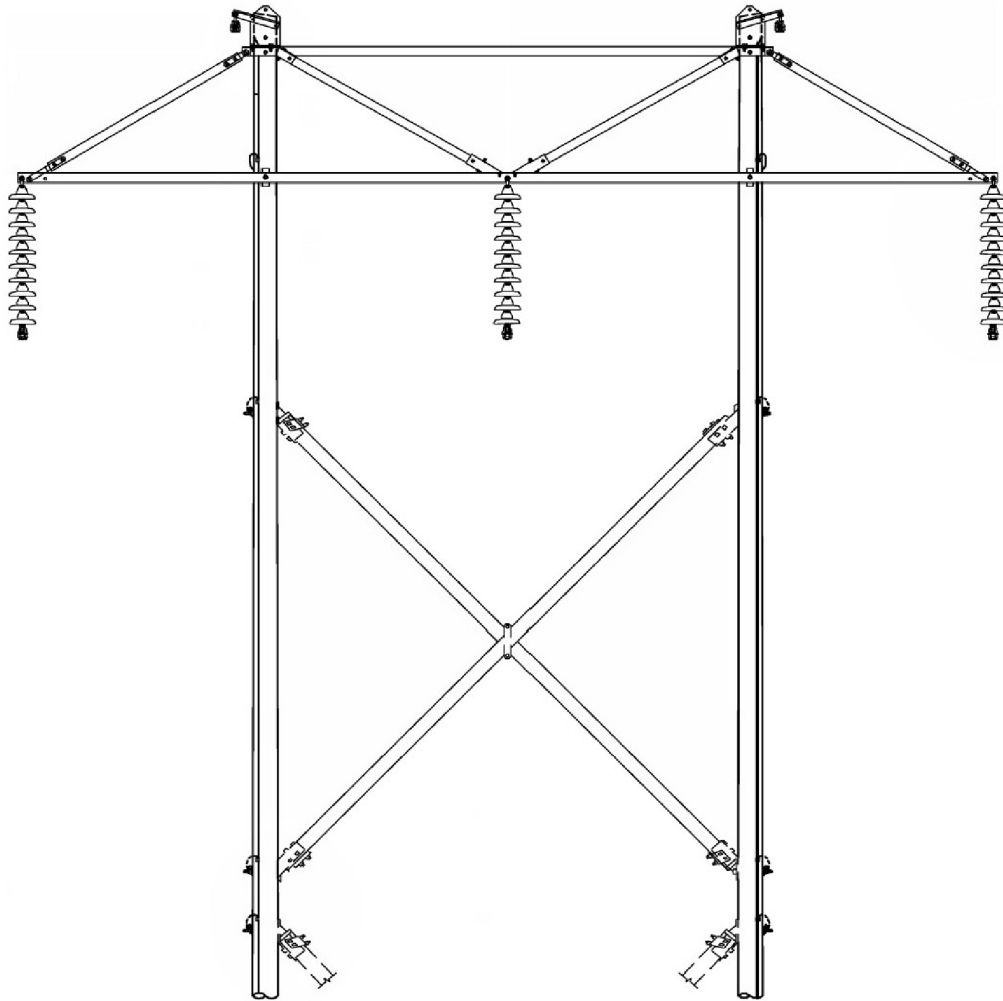

FIGURE H-2A

Rev. 2

Typical Design of a Single-Circuit
Double Wood Pole H-Frame Structure

**EAGLE ROCK ENRICHMENT FACILITY
ENVIRONMENTAL REPORT**

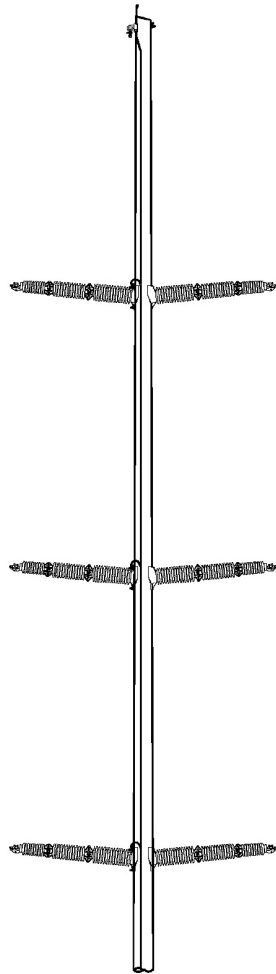

FIGURE H-2B

Rev. 2

Typical Design of a Double-Circuit
Single Wood or Steel Pole Structure

**EAGLE ROCK ENRICHMENT FACILITY
ENVIRONMENTAL REPORT**

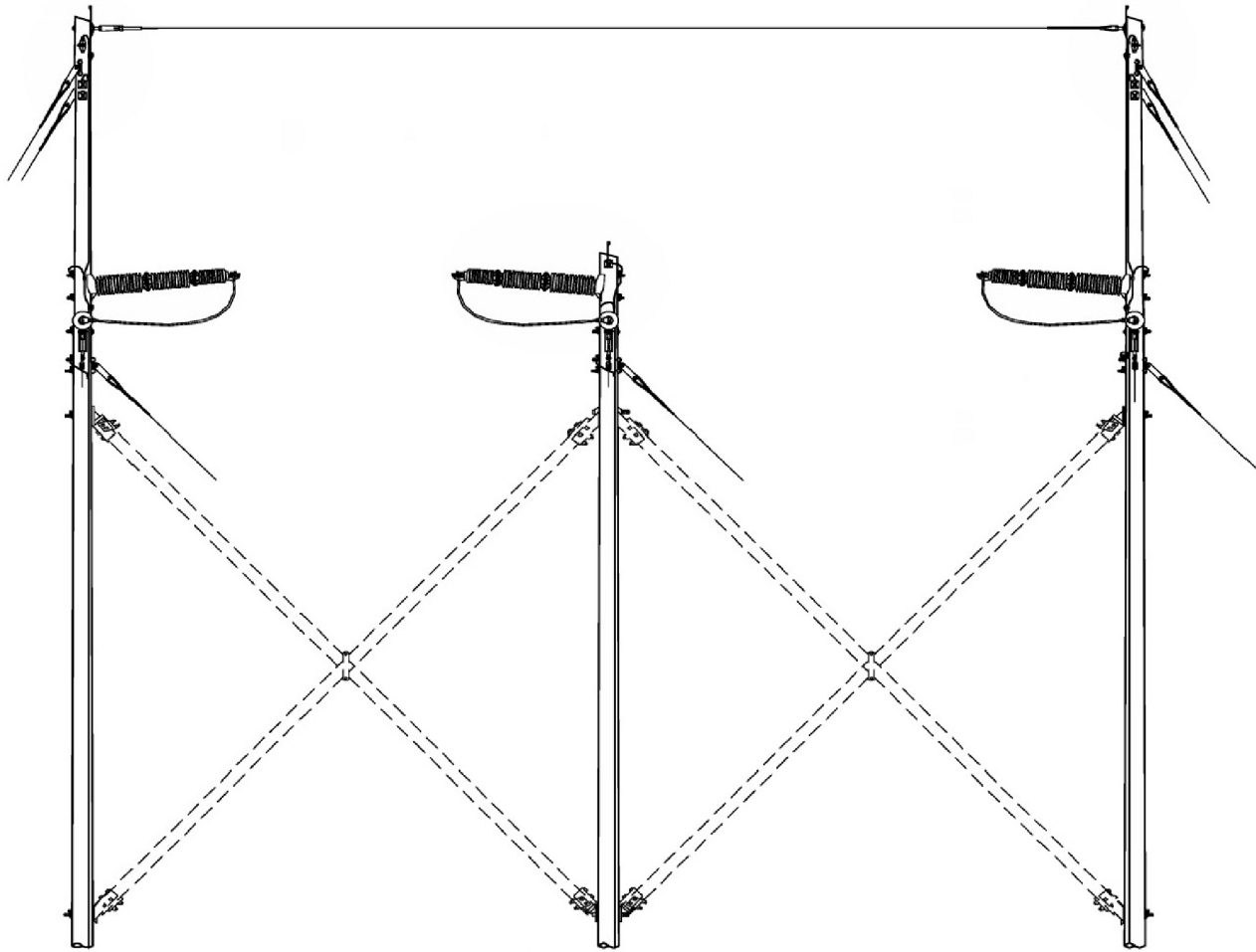

FIGURE H-2C

Rev. 2

Typical Design of a 3-Pole
Dead-End Structure

**EAGLE ROCK ENRICHMENT FACILITY
ENVIRONMENTAL REPORT**

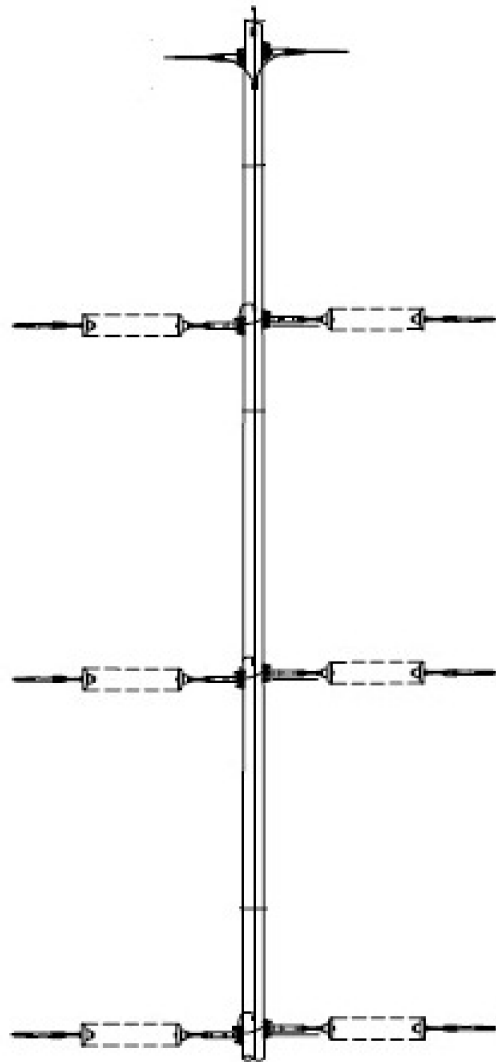

FIGURE H-2D

Rev. 2

Typical Design for a Single-Pole
Steel Dead-End Structure

**EAGLE ROCK ENRICHMENT FACILITY
ENVIRONMENTAL REPORT**

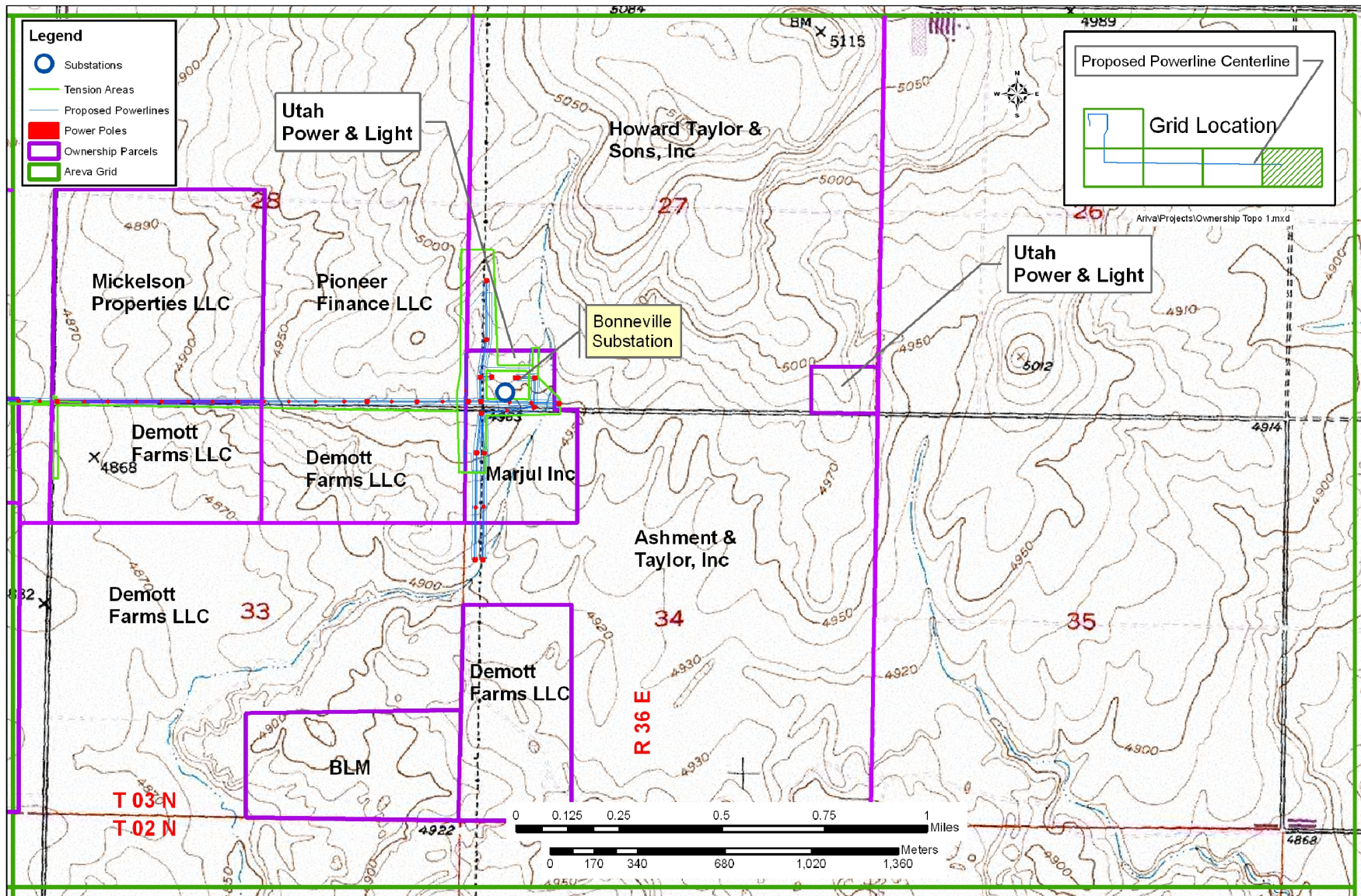

FIGURE H-3 **Rev. 2**
 Private Property Ownership
 (Sheet 1 of 5)
**EAGLE ROCK ENRICHMENT FACILITY
 ENVIRONMENTAL REPORT**

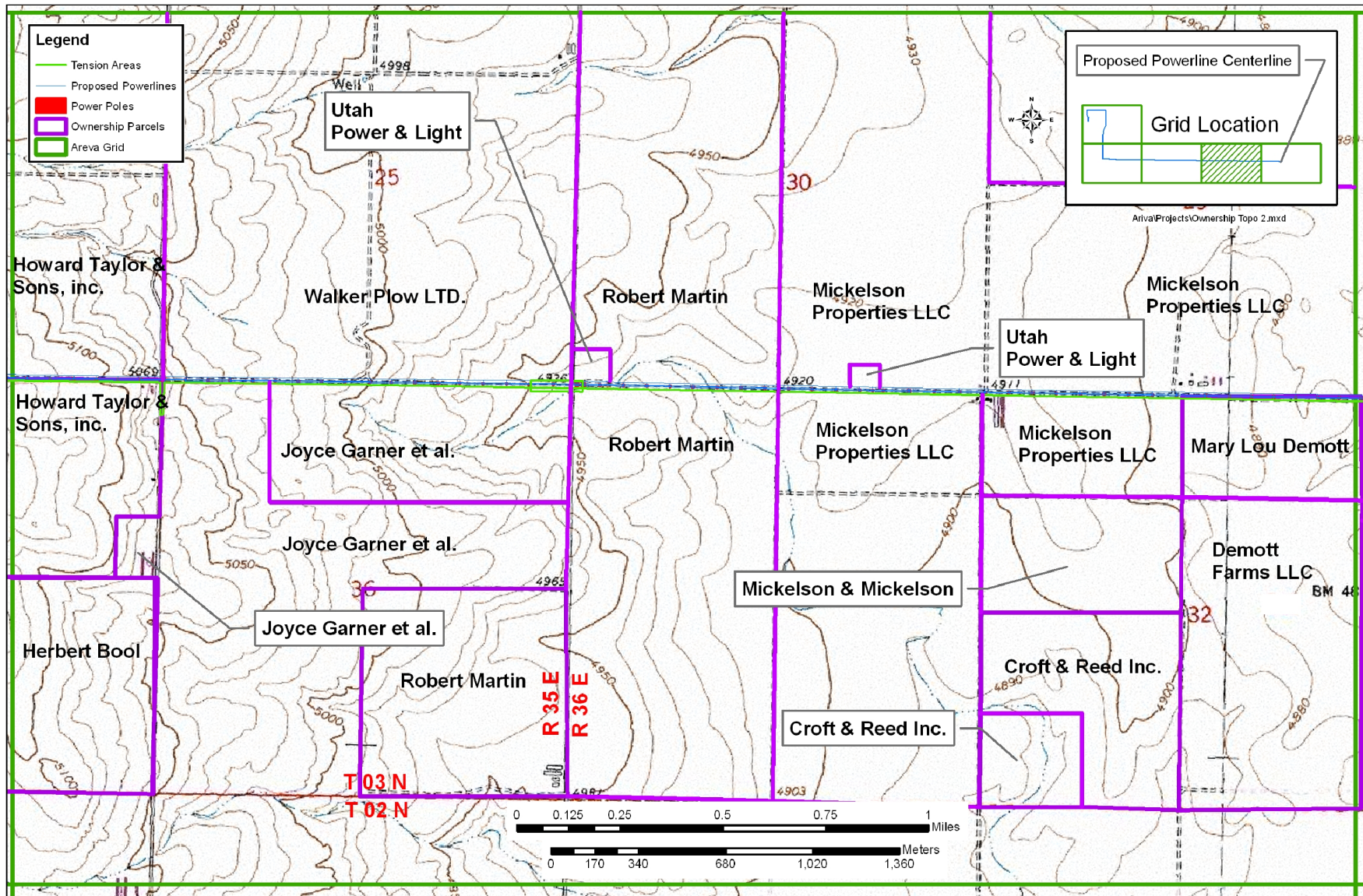

FIGURE H-3 **Rev. 2**
 Private Property Ownership
 (Sheet 2 of 5)
**EAGLE ROCK ENRICHMENT FACILITY
 ENVIRONMENTAL REPORT**

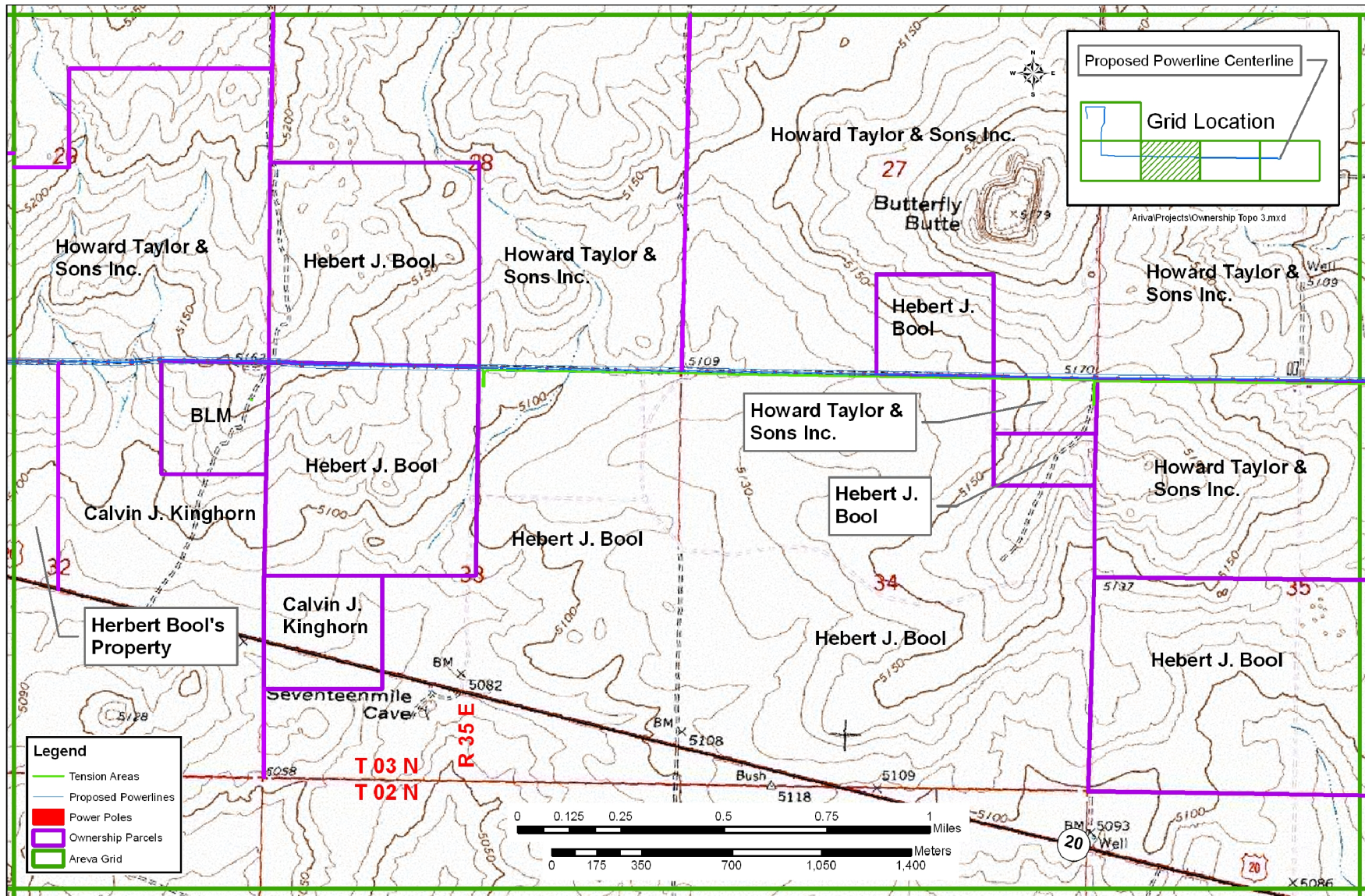

FIGURE H-3 **Rev. 2**
Private Property Ownership
(Sheet 3 of 5)
**EAGLE ROCK ENRICHMENT FACILITY
ENVIRONMENTAL REPORT**

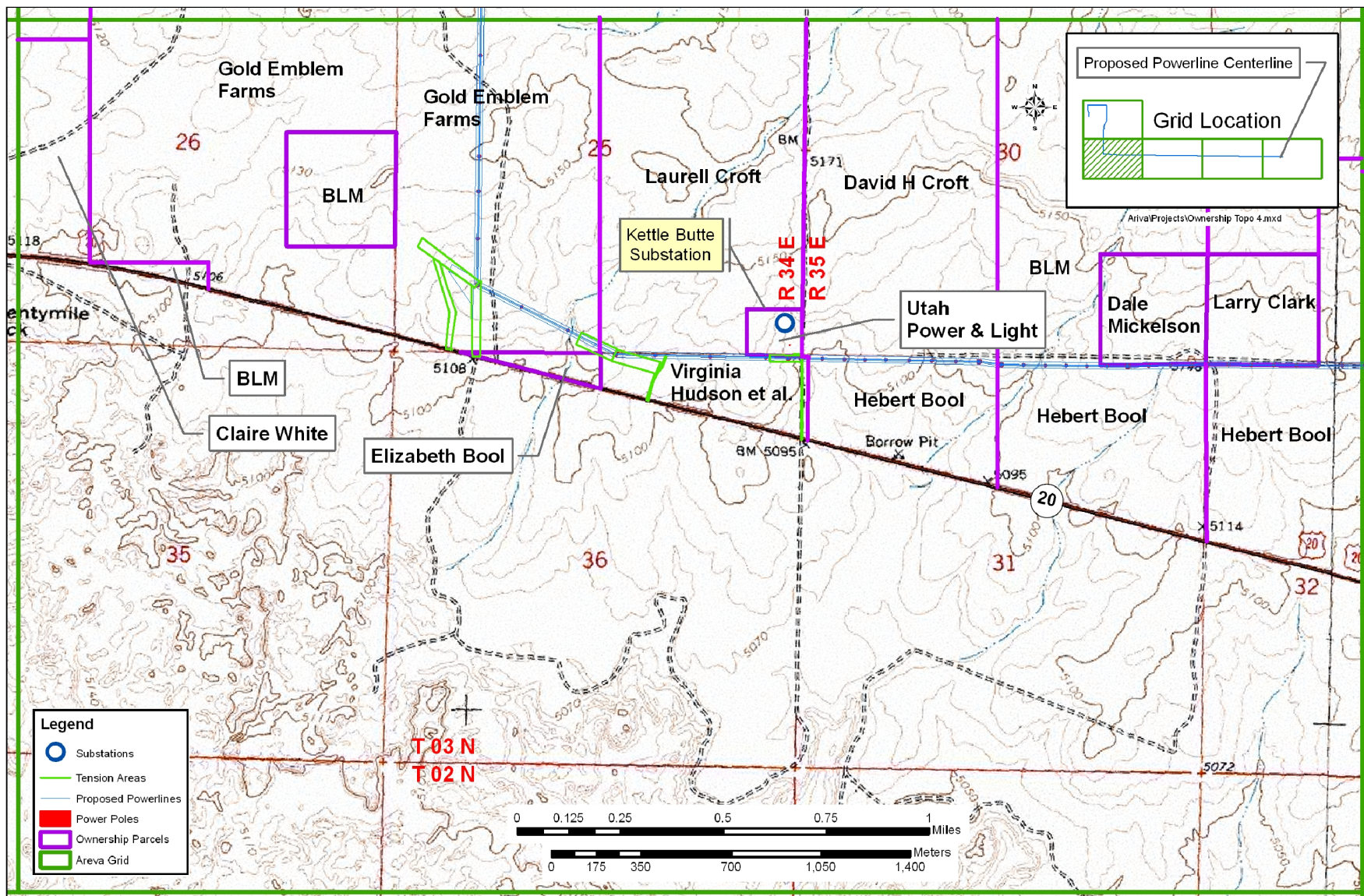

FIGURE H-3 **Rev. 2**
 Private Property Ownership
 (Sheet 4 of 5)
**EAGLE ROCK ENRICHMENT FACILITY
 ENVIRONMENTAL REPORT**